

Conley Composites

an ANDRONACO INDUSTRIES company

*Thank You, **VALUED CUSTOMERS***, for your interest in Conley Piping Systems. Please allow us to further acquaint you with our Products and Services. Conley Piping Products have performed successfully in corrosive environments for nearly half a century. We co-invented the FRP industry as the world's first FRP fitting manufacturer, and built the first FRP valves in 1953. We manufacture Conley Fittings and Valves in accordance with ASTM D-2996, the filament winding process. We believe our unique 3-stage process produces superior FRP performance, reliability and safety.

Fitting manufacturing begins with the finest raw materials available: premium Epoxy resins from Shell Chemical, Ciba-Geigy, and The Dow Chemical Co.; Vinyl Ester resins from The Dow Chemical Co. and Ashland Chemical Co., and Furan resin from QuaCorr and Ashland. **All Fittings begin with a STANDARD minimum double Nexus reinforced inner liner, (CORROSION BARRIER), available in Epoxy, Vinyl Ester, or Furan depending upon the chemical and mechanical service requirements.** Conley Fittings are available in **STANDARD** Nexus veil reinforced 60 mil or 100 mil Internal Corrosion Barriers, with fire retardant and abrasion resistant resin systems available in addition to our standard options. We construct the filament wound CAGE with aromatic amine cured Epoxy saturated finely woven E-Glass fabric and continuous strand for outstanding HDT performance (Heat Distortion Temperature=over 300°F), with both medium and extra heavy duty structural reinforcement available. Finally, we encapsulate our fittings with our standard Nexus reinforced External Corrosion Barrier with UV inhibitors, and all fittings have a standard 25 year guarantee against UV degradation, or "fiber-blooming". In addition to corrosion resistance, the final layer also provides increased impact resistance, and allows custom color when requested. Since there is no fiberglass in the exterior layer lung, eye, and skin irritation associated with airborne fiberglass particles during preparation for joining is eliminated. Conley uses the straight socket system of joining for speed and simplicity of fabrication.

All Conley Fittings are post cured in electronically monitored ovens to insure optimum performance of the resin system. This process chemically bonds all three layers into one integral composite laminate structure. We electronically gauge the corrosion barrier of every fitting to the nearest 1 mil for proper thickness. Every lot of resin, every bulk mix, and every batch is sampled and tested for reactivity and cure. Each and every fitting is heat shocked from 250°F to 36°F, impact tested, dimensionally checked, and visually inspected before the Quality Assurance stamp goes on. **We are serious about quality at Conley with 100% of our work force dedicated to Quality, and 12% devoted to the Quality Assurance Department.**

Conley is moving into the 21st century with our ongoing "Commitment to Excellence" in product, service, and technical innovation. This commitment is responsible for a new line of **Basket Strainers, Straight-Thru Diaphragm Valves, Dual Containment Valves, Dual Containment Expansion Joints**, as well as the technology to encapsulate valves from other manufacturers. Conley can provide full engineering services, CAD disks, and of course, our Field Technical Services are available for technical advice, fabrication seminars, and on the job site supervision. It is standard procedure for the Conley Technical Committee to assist with design parameters, resin selection, and other advisory functions.

[We are at your service.](#)



4544 Broadmoor Ave. SE, Kentwood, MI 49512 USA Phone: 616.512.8000 Fax: 616.512.8001

CONTENTS



CONLEY FITTINGS SPECIFICATIONS

Conley Composites Corrosion Resistant Engineered Fittings have nearly half a century history of successful performance in aggressive chemical environments. Technical innovation as well as our ongoing "Commitment to Excellence" have made Conley Fittings the benchmark of quality in the FRP Piping Industry. Our fittings are manufactured in a unique 3-stage process:

INTERNAL CORROSION BARRIER

We begin the standard Conley Fittings, Schedule 30, 40, and 50 with a **minimum double synthetic veil reinforced** resin rich internal corrosion barrier (inner liner), 60 mils minimum (Schedule 50=100 mils), per the recommendations of the resin manufacturers to improve chemical, impact, and abrasion resistance. The hand lay-up corrosion barrier is manufactured with premium resins including Epoxy (Shell 828, Ciba 6010, D.E.R.331™ *), Vinyl Ester resin (Derakane™ * 441-400, 470, 8084, 510 series), or Furan resin (QuaCorr). Corrosion Barrier resin selection is based upon the resin best suited for the chemical, mechanical and temperature requirements of the service application. Abrasion resistant, fire retardant and conductive resin systems are available. This layer shall be a maximum of 90% resin and 10% reinforcement to increase impact resistance.

FILAMENT WOUND CAGE

Conley Filament Wound Fittings are reinforced with alternating layers of glass cloth for axial strength, and continuous E-Glass strand for hoop strength, The structural cage of our fittings is saturated with aromatic amine cured Epoxy resin, selected by Conley engineers for the high HDT performance (over 300°F). This layer provides the renowned Conley Fittings strength, and a higher structural safety factor in Vinyl Ester and Furan fittings at elevated temperatures.

EXTERNAL CORROSION BARRIER

Conley Fittings are encapsulated with a Nexus reinforced external corrosion barrier to insure chemical resistance against spillage, impact resistance, and to provide a UV barrier that allows Conley to extend a 25 year guarantee against UV light degradation, or "fiber-blooming". Custom color is available upon request for line code designation.

All Conley Fittings are oven post-cured for optimum performance of the resin system. Each fitting is carefully monitored through all stages of manufacture including: Sampling and testing of every batch of resin, Barcol hardness, electronic measurement of laminate compliance to 1 mil accuracy, heat shock from 250°F to 36°F, impact testing, hydro-testing, and final visual inspection before it receives the QA stamp of approval.

*Trademark of the Dow Chemical Company

CONTENTS

SIZE IN.	A	B	C	D	E	WT. LBS.
1/2	1 3/4	7/8	7/8	3	3/4	0.4
3/4	1 13/16	1	13/16	3 1/2	7/8	0.6
1	2 1/8	1 1/4	7/8	3 1/2	1 1/16	1.5
1 1/2	2 9/16	1 5/16	1 1/4	4	1 1/16	2.1
2	3 3/16	1 1/2	1 11/16	4 1/2	1 3/16	3.1
2 1/2	3 3/4	1 3/4	2	5	1 1/4	4.1
3	4 1/4	2	2 1/4	5 1/2	1 1/4	5.2
4	5 5/8	2 5/8	3	6 1/2	1 5/8	10.1
6	7 5/8	3 1/2	4 1/8	8	1 1/2	15.5
8	8 5/8	3 3/4	4 7/8	9	1 5/8	21.1
10	10 3/8	4	6 3/8	11	1 3/4	37.0
12	12 3/4	4 1/2	8 1/4	12	2 1/8	58.0
14	15 1/8	4 3/4	10 3/8	14	2 1/2	78.0
16	15 1/2	5 3/8	10 1/8	16	2 3/4	98.5
18	17 9/16	5 3/8	12 3/16	16 1/2	3	119.5
20	19 3/8	5 3/8	14	18	3 1/4	149.0
24	36	9	27	36	*	-
30	45	12	33	45	*	-

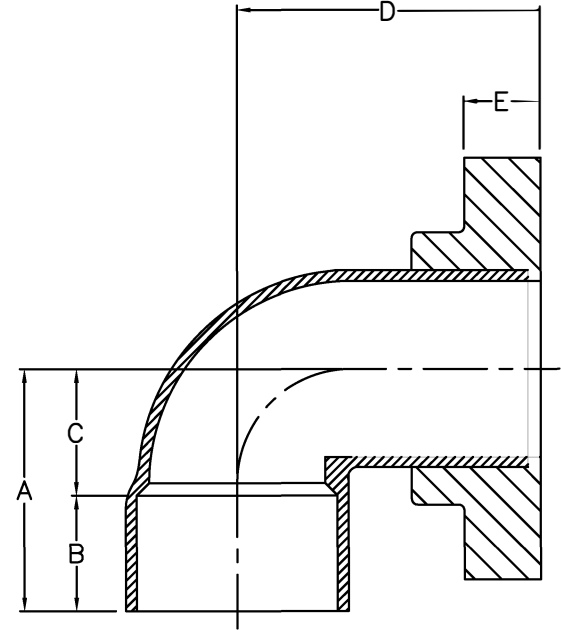

SPECIFICATION DRAWING
#108 FLG X CEM 90° ELL

108(R2)

* PER SPECIFIC APPLICATION

SIZE IN.	A	B	C	D	E	WT. LBS.
1/2	1 1/8	7/8	1/4	1 3/4	3/4	0.3
3/4	1 1/2	1	1/2	2 1/4	7/8	0.4
1	1 7/8	1 1/4	5/8	1 3/4	1 1/16	1.3
1 1/2	2 5/16	1 5/16	1	2 1/4	1 1/16	1.8
2	2 9/16	1 1/2	1 1/16	2 1/2	1 3/16	3.4
2 1/2	3 1/4	1 3/4	1 1/2	3	1 1/4	4.1
3	3 5/8	2	1 5/8	3	1 1/4	4.5
4	4 1/2	2 5/8	1 7/8	4	1 5/8	7.5
6	5 1/2	3 1/2	2	5	1 1/2	11.2
8	6 7/16	3 3/4	2 11/16	5 1/2	1 5/8	17.0
10	7 9/16	4	3 9/16	6 1/2	1 3/4	29.5
12	8 7/8	4 1/2	4 3/8	7 1/2	2 1/8	47.0
14	9 3/4	4 3/4	5	8 1/2	2 1/2	62.0
16	11 1/4	5 3/8	5 7/8	9	2 3/4	79.5
18	11 7/8	5 3/8	6 1/2	9 1/2	3	94.0
20	12 1/4	5 3/8	6 7/8	10 1/2	3 1/4	119.5
24	24	9	15	24	*	-
30	30 5/8	12	18 5/8	30	*	-

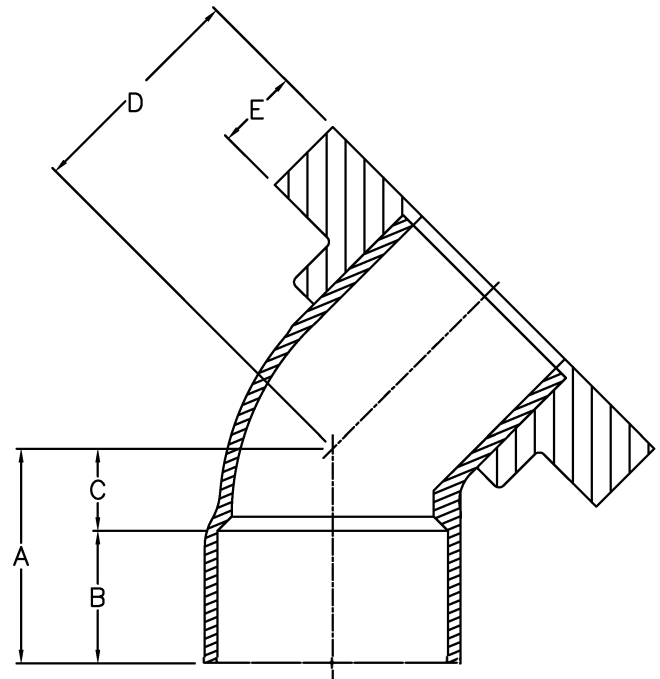

SPECIFICATION DRAWING
#109 FLG X CEM 45° ELL

* PER SPECIFIC APPLICATION

SIZE IN.	A	B	C	D	WT. LBS.
1/2	2 11/16	7/8	15/16	3	0.5
3/4	3 5/8	1	1 5/8	3 1/2	0.8
1	4 1/4	1 1/4	1 3/4	3 1/2	1.7
1 1/2	5 1/4	1 5/16	2 5/8	4	2.3
2	6 3/8	1 1/2	3 3/8	4 1/2	3.5
2 1/2	7 1/8	1 3/4	3 5/8	5	4.8
3	8 1/4	2	4 1/4	5 1/2	6.2
4	11	2 5/8	5 3/4	6 1/2	13.6
6	15	3 1/2	8	8	17.6
8	17 1/4	3 3/4	9 3/4	9	22.6
10	20 3/4	4	12 3/4	11	33.0
12	24	4 1/2	15	12	50.6
14	28	4 3/4	18 1/2	14	82.0
16	32	5 3/8	21 1/4	15	111.6
18	34 3/4	5 3/8	24	16 1/2	138.0
20	37 1/4	5 3/8	26 1/2	18	170.0
24	66	9	48	24	-
30	84	12	60	30	-

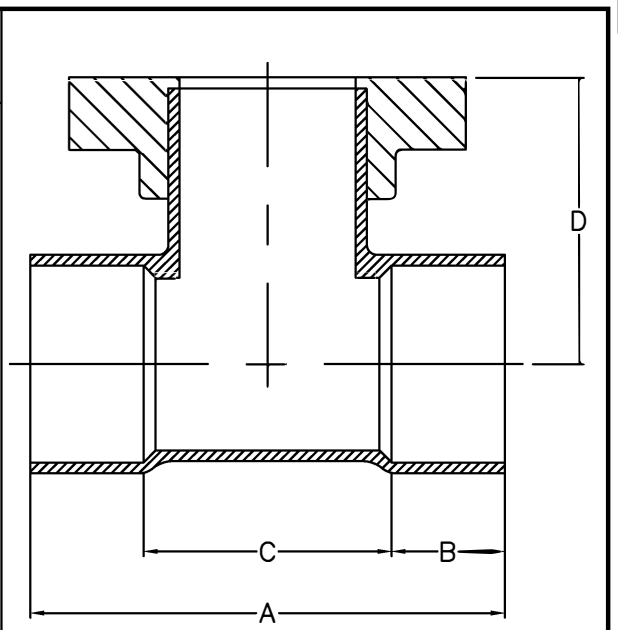

NOTE: DIMENSIONS APPLY TO ALL FLG X SOCKET CONFIGURATIONS.

Conley Composites
an ANDRONACO INDUSTRIES company

SPECIFICATION DRAWING
#110 CEM X CEM X FLG TEE